

RECEIVED
 JUN 18 1981

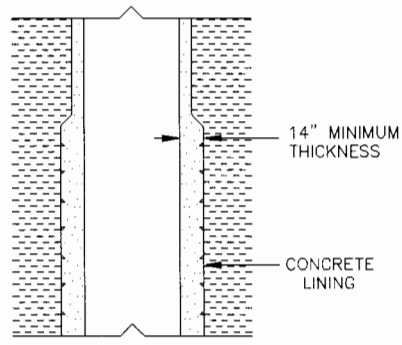

This Illustration for Information Purposes only.

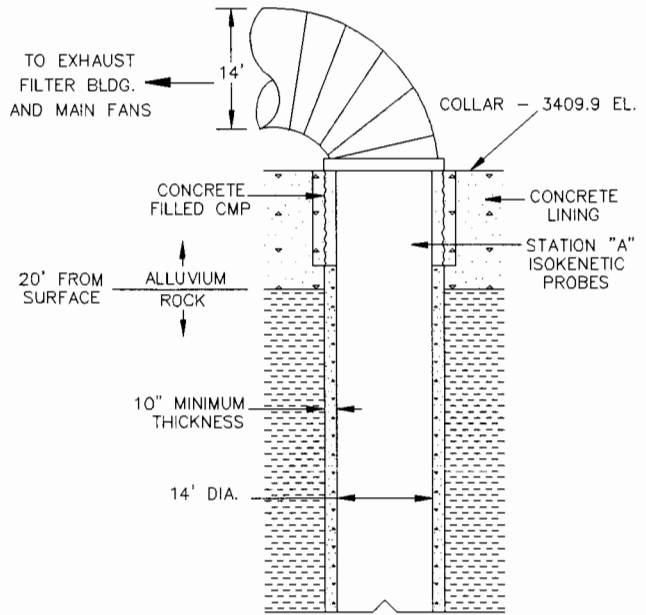

COLLAR

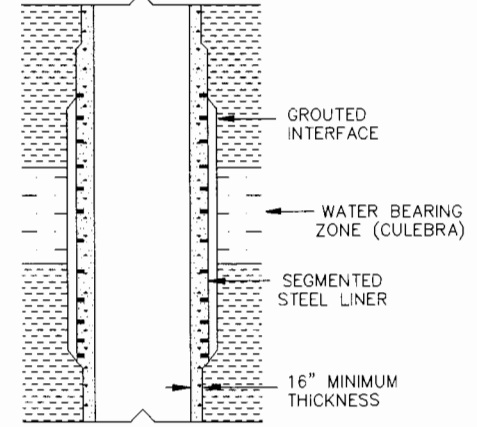
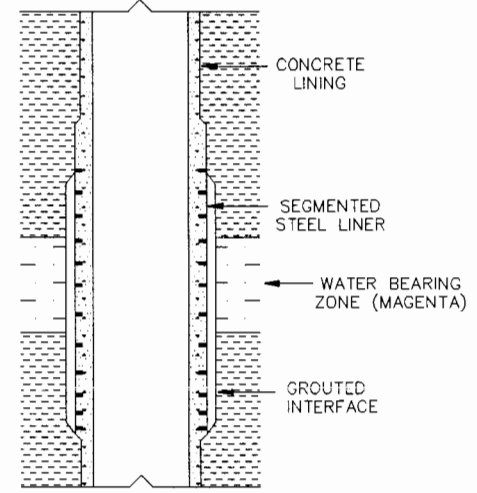

WATER BEARING ZONE SEALS

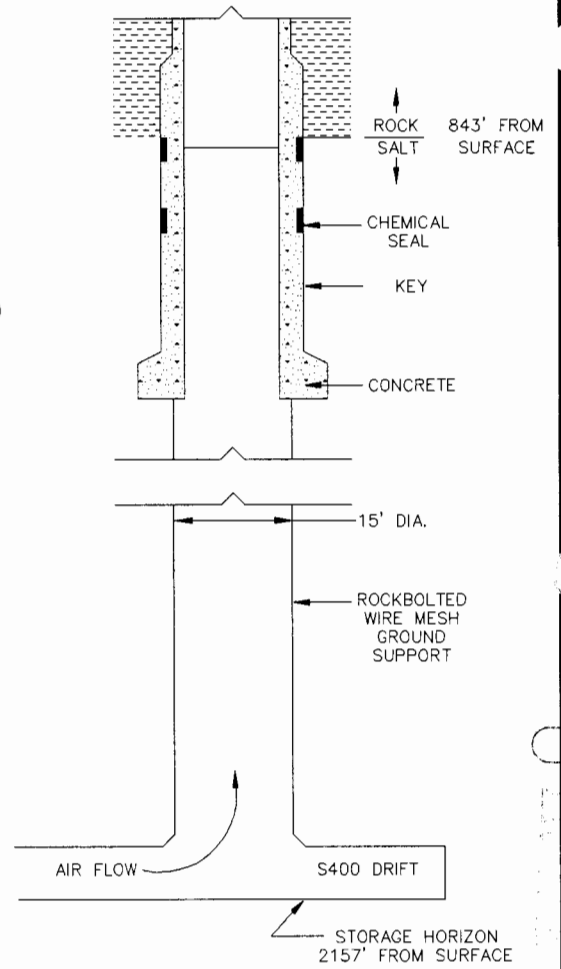

KEY & STATION

FIGURE 3-7. Exhaust Shaft

X-X



Underground Water Volumes

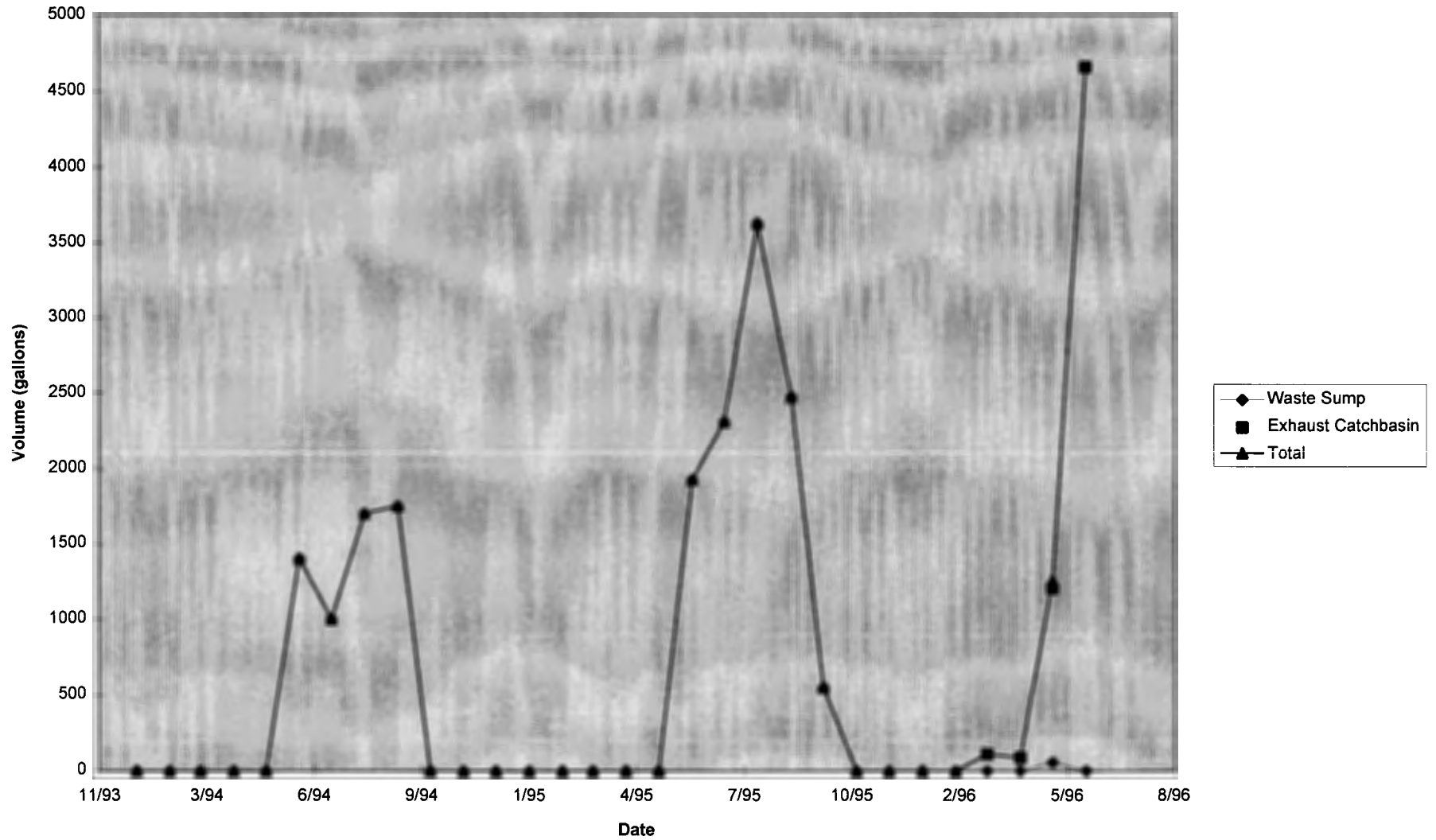



SUMMARY OF LEAD ANALYTICAL RESULTS
SAMPLING 1/19/96 - 1/23/96

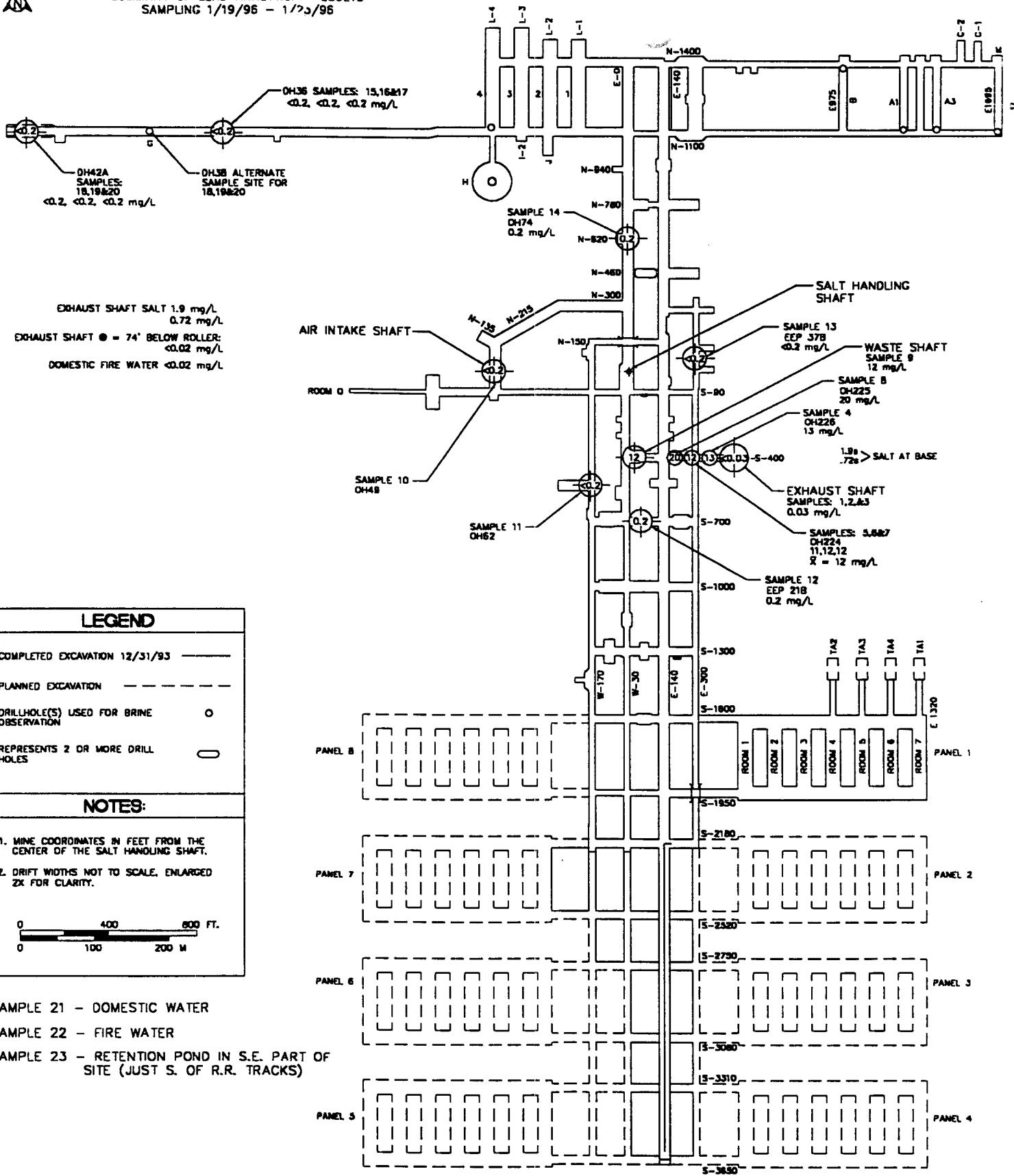

MAP OF WIPP UNDERGROUND SHOWING
PROPOSED SAMPLING LOCATIONS

FIGURE 1

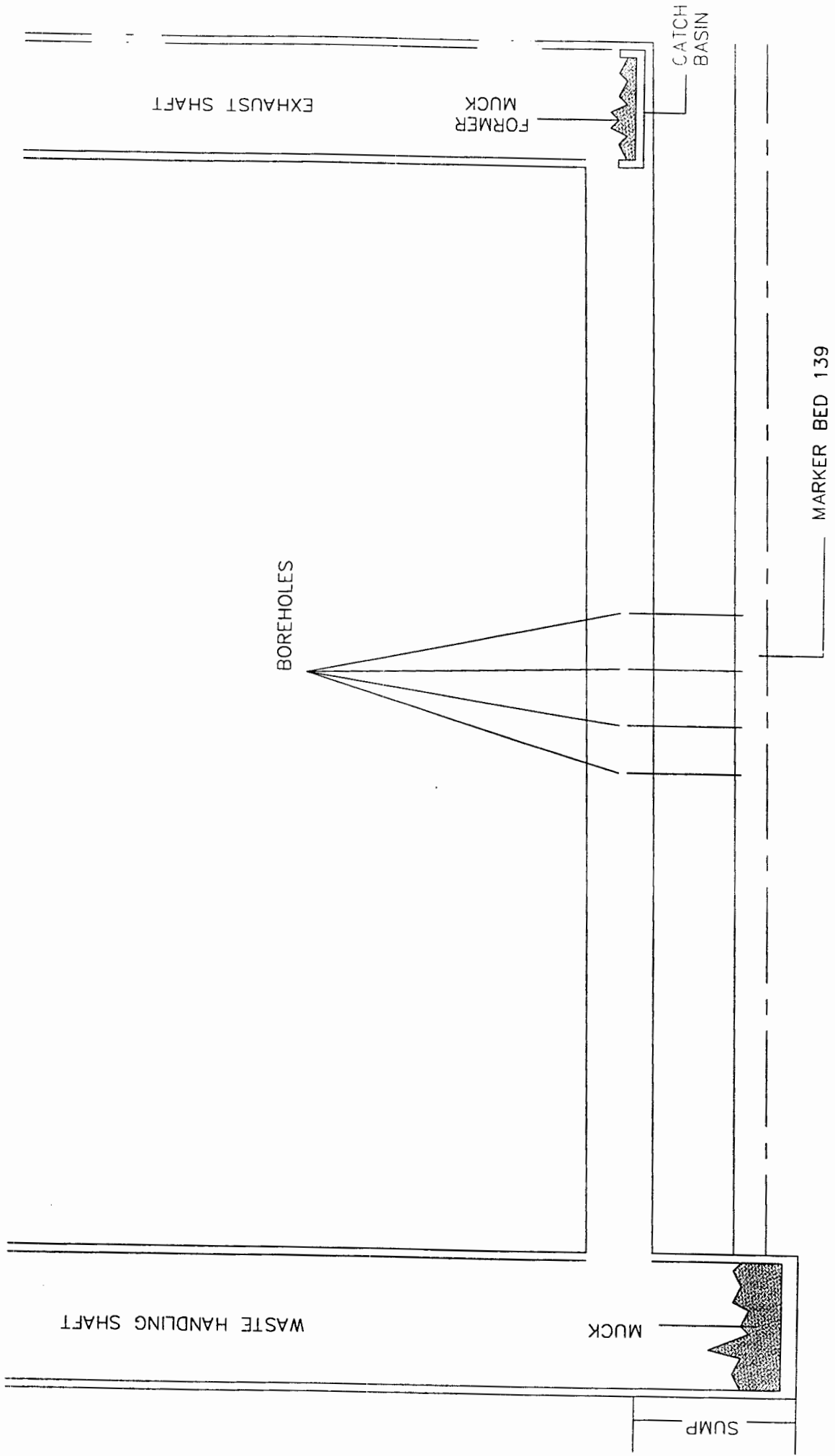

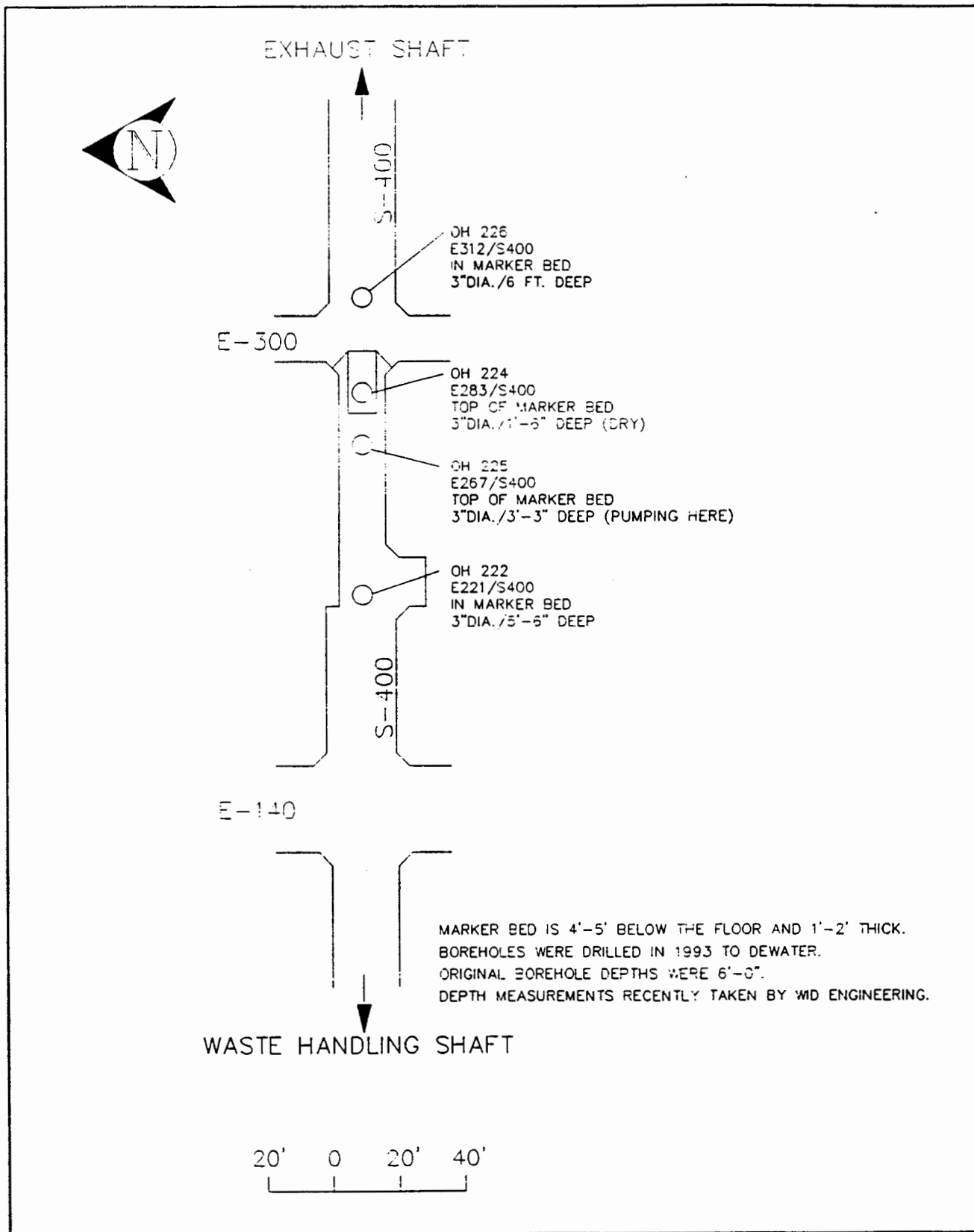

S400 BOREHOLES

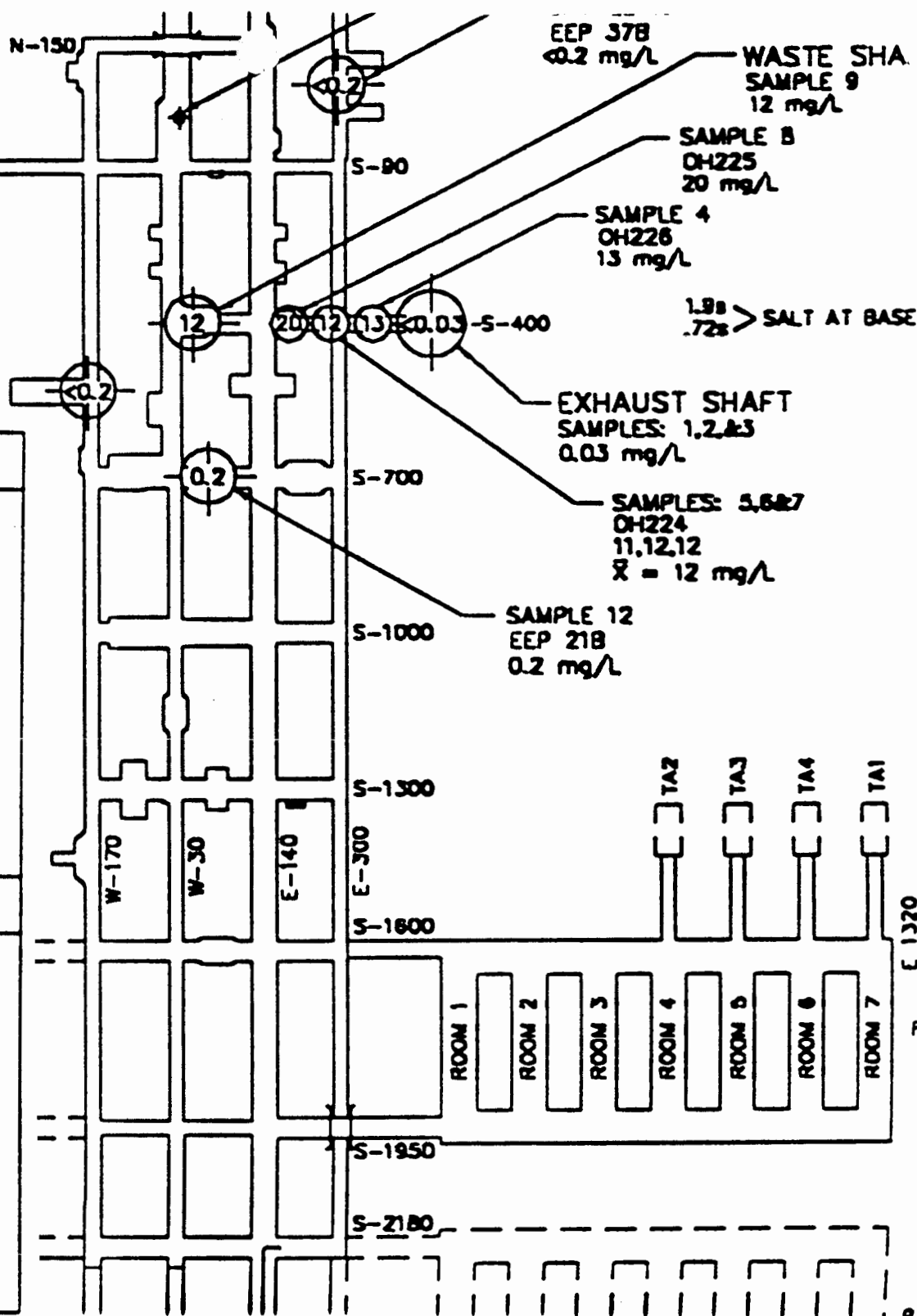
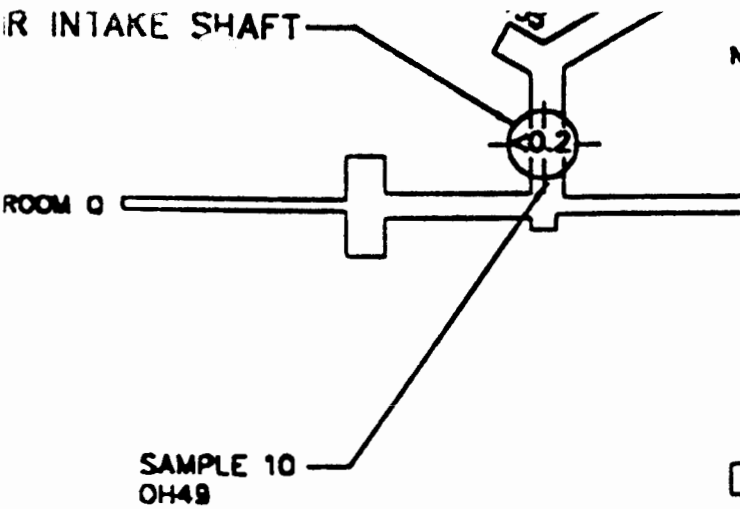

LEGEND

- COMPLETED EXCAVATION 12/31/93
- PLANNED EXCAVATION
- DRILLHOLE(S) USED FOR BRINE OBSERVATION
- REPRESENTS 2 OR MORE DRILL HOLES

NOTES:

1. MINE COORDINATES IN FEET FROM THE CENTER OF THE SALT HANDLING SHAFT.
2. DRIFT WIDTHS NOT TO SCALE, ENLARGED 2X FOR CLARITY.

